



Super Finishing Machines

Inner Ring and Outer Ring of a Ball Bearing

SMT Systems LLP

Pune, India



About SMT

- ▶ SMT Systems llp (India) has been founded by two technocrats from SKF; Mr. Santosh Habade and Mr. Mahendra Patel; having experience of more than 20 years each in bearing industry
- ▶ SMT is specialist in developing Bearing Assembly and Testing Machines and complete assembly channels for various types of bearings such as DGBB, TRB, SRB, CRB, ACB, WPB etc.
- ▶ SMT has now started developing Super Finishing Machines with Italian Expert Mr. Luigi Paglia
- ▶ SMT offers following three honing machines for DGBB rings:
 - ▶ Multi stone Inner Ring Honing Machine with Single set of rollers (IRH-45-1R)
 - ▶ Multi stone Inner Ring Honing Machine with Double Set of rollers (IRH-45-2R) and
 - ▶ Double station (Rough and Finish) Outer Ring Honing Machine ORH-72
- ▶ All machines are with new innovative concepts, modern electronics and good aesthetics
- ▶ Cost competitive world wide.



IRH-1R: Inner Ring Honing (Single Row)

- ▶ Suitable for Inner Ring up to 45 mm OD
- ▶ Cycle time 5 sec
- ▶ Resetting time 45 min
- ▶ Roughness Results 0.02 micron
- ▶ Compact design

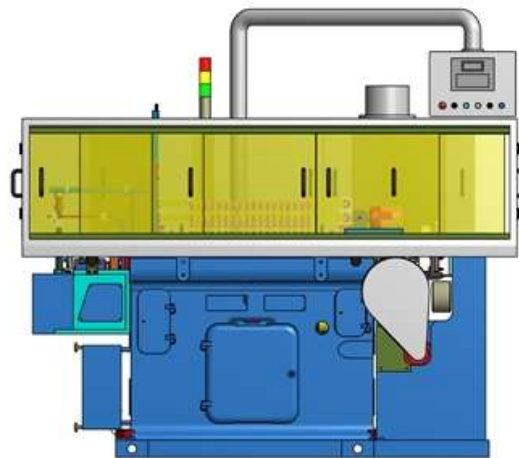
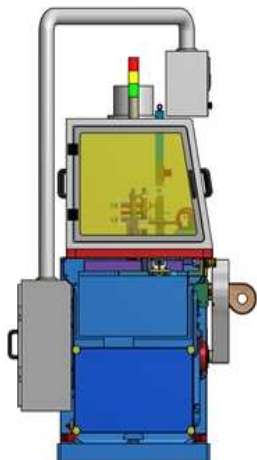
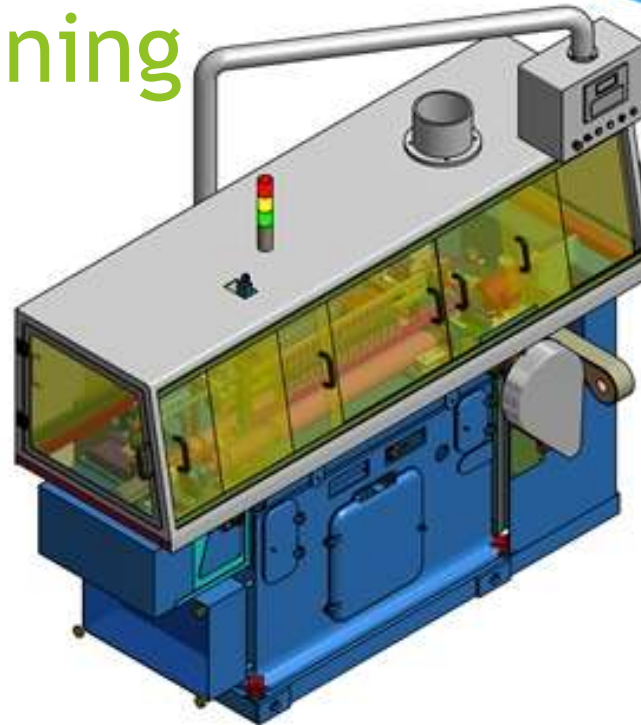

Machine Details

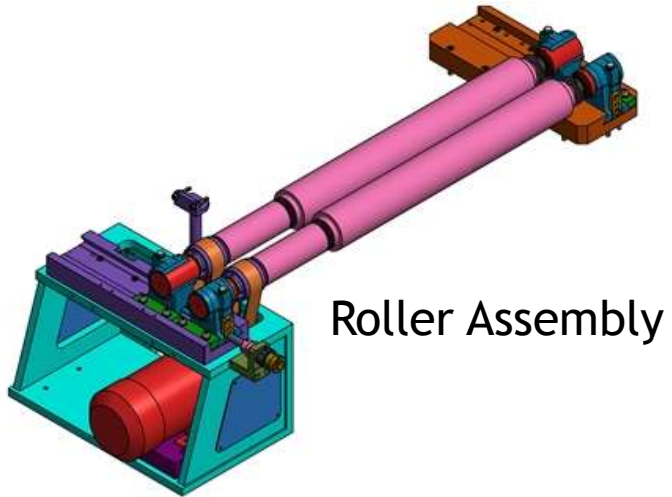

Roller Assembly

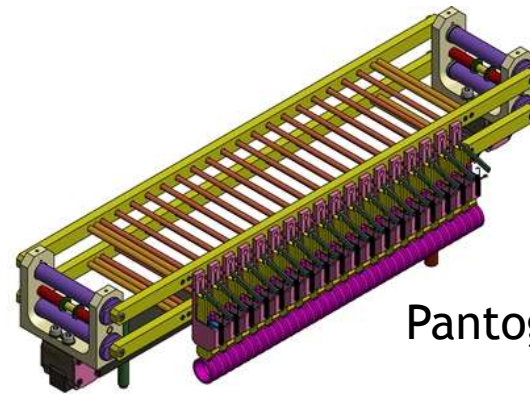

Pantograph Assembly

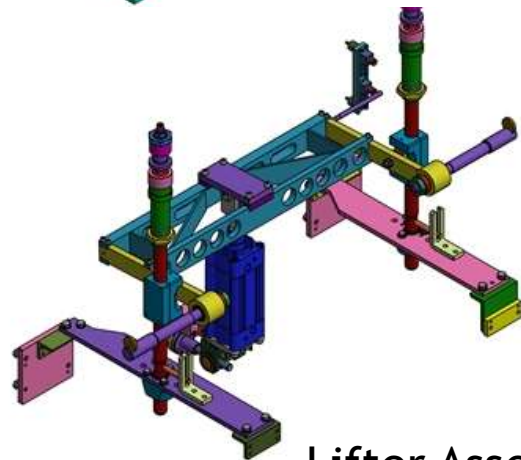

Lifter Assembly

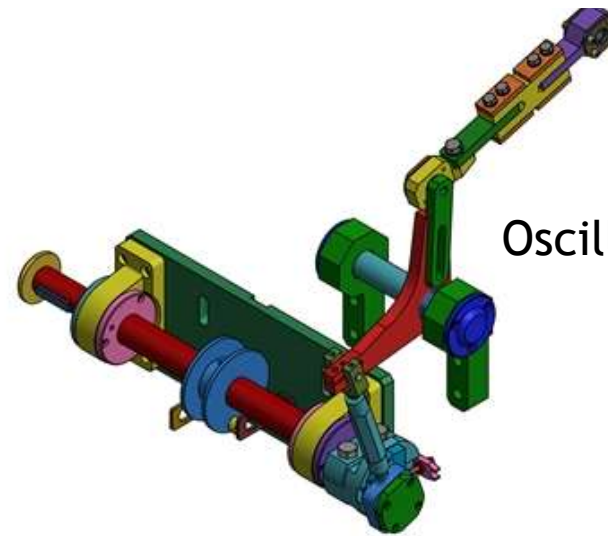

Oscillation Assembly



IRH -45-2R Inner Ring Honing Double Row

- ▶ Suitable for Inner Ring up to 45 mm OD
- ▶ Cycle time 2.5 sec
- ▶ Resetting time 60 min
- ▶ Roughness Results 0.02 micron
- ▶ Compact design

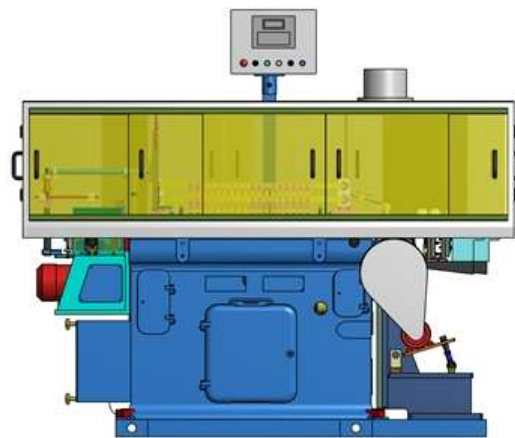
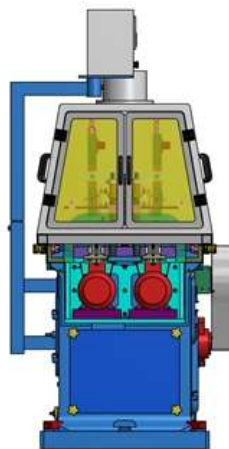
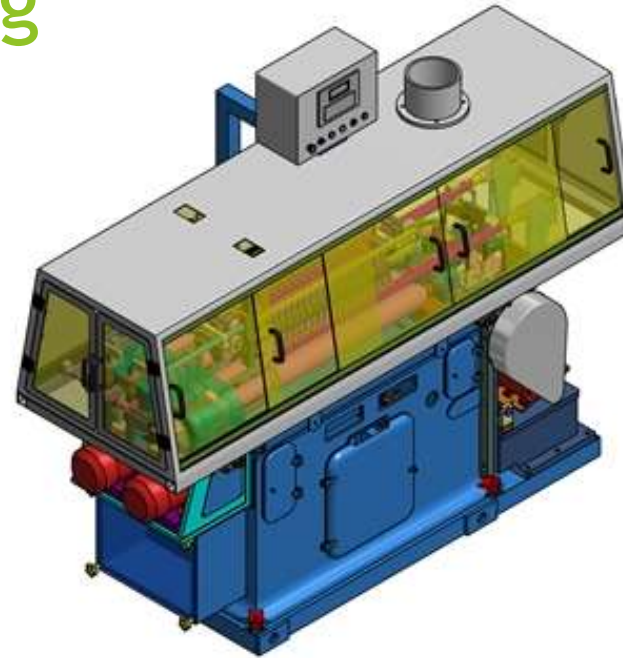



Machine Details

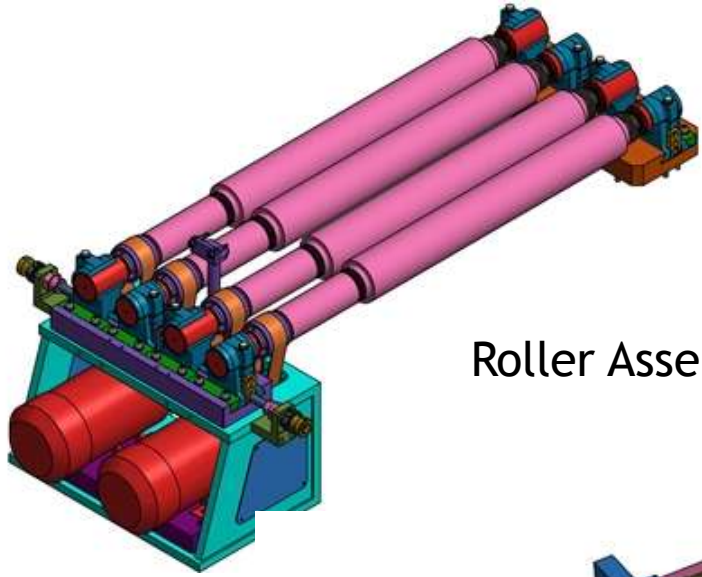

Roller Assembly

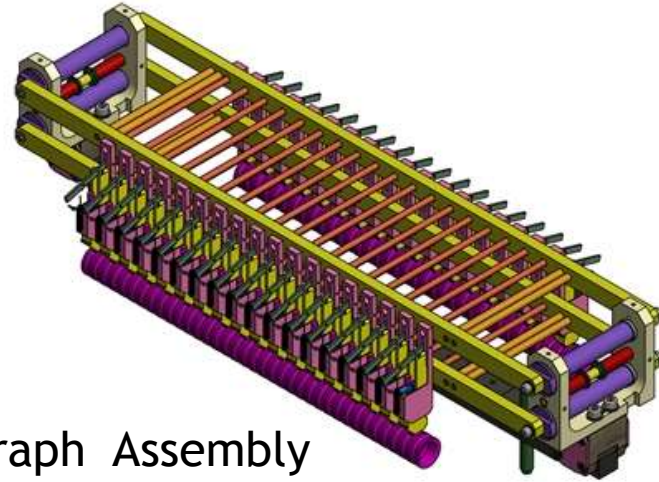

Pantograph Assembly

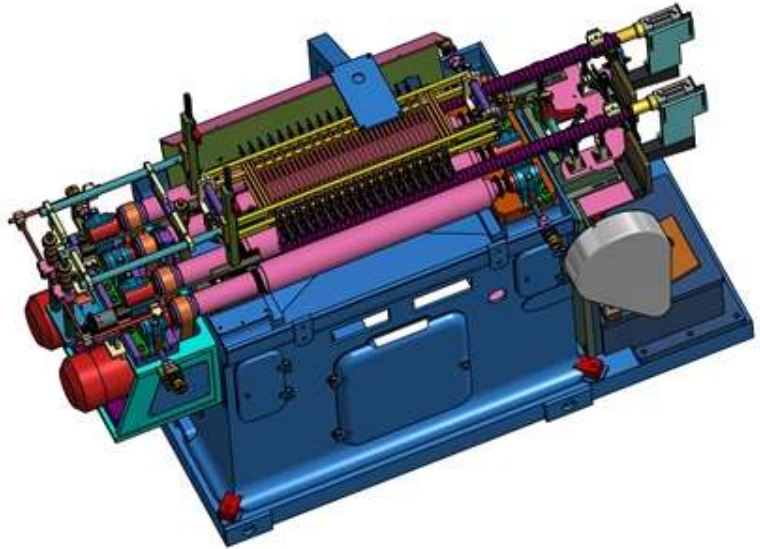

Internal View



ORH -72 Outer Ring Honing

- ▶ Suitable for Outer Ring up to 72 mm OD
- ▶ Cycle time 9 sec
- ▶ Resetting time 45 min
- ▶ Roughness Results 0.02 micron
- ▶ Compact design

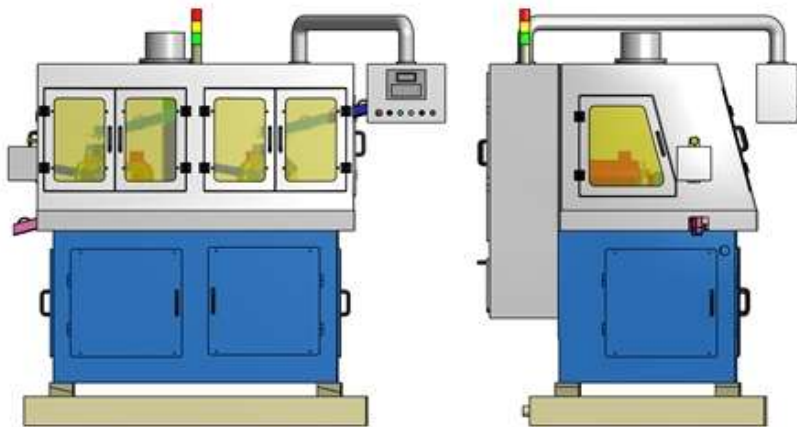
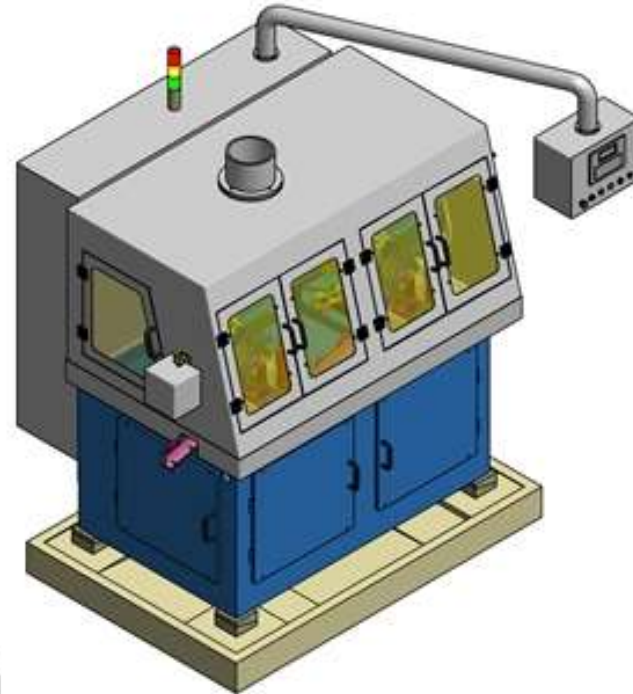



Machine Details

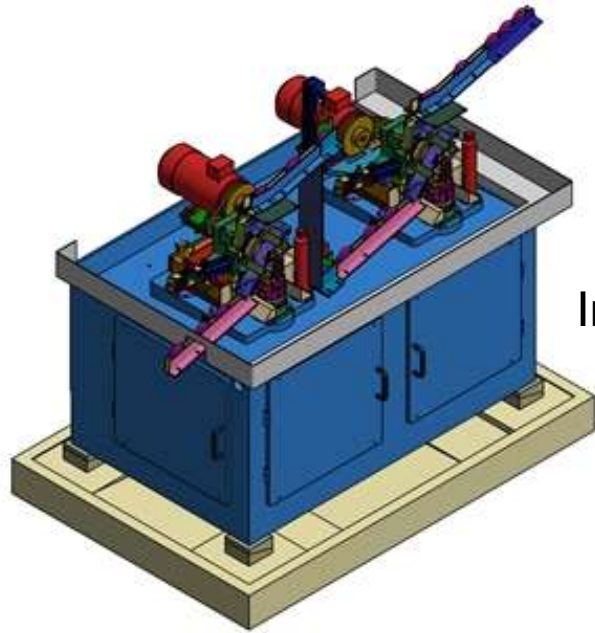

Inside View

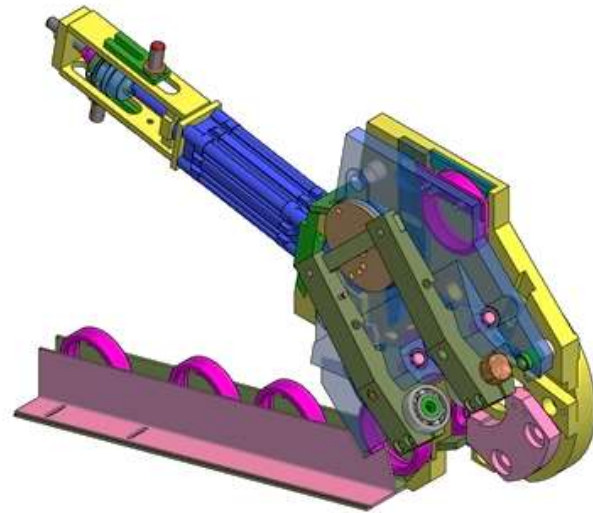

Chuck Assembly

Driving Spindle



Oscillation Spindle

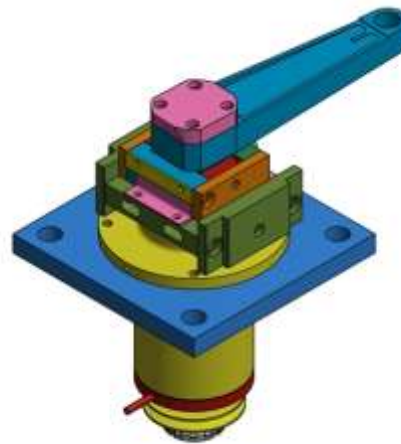

About Mr. Luigi Paglia



- ▶ Association with SKF since 1962 and SKF India from 1994 to 2015
- ▶ Development of complete Channel for bearing manufacturing
- ▶ Expert in Grinding, Superfinishing and assembly machine.
- ▶ Now associated with SMT Systems LLP (India)
- ▶ Achievements
 - ▶ Grinding Machines 30+
 - ▶ Honing Machines 30+
 - ▶ Assembly machines 140+
 - ▶ Complete Channels 10+
 - ▶ And still counting



Thank You

SMT System LLP

Plot 146, Sector 10, PCNTDA, Bhosari, Pune 411026
Maharashtra, INDIA

Email: smpune@yahoo.com

Santosh Habade : +919822400930

Luigi Paglia : +919850823020